

Electronic Module for Data Acquisition and Transmitting for Portable Power Steering Test Equipment

Dipl. Eng. **Alexandru HRISTEA**¹, PhD. Eng. **Radu RĂDOI**¹,
Dipl. Eng. **Bogdan TUDOR**¹, Eng. **Ion BĂLAN**¹

¹ INOE 2000-IHP, hristea.ihp@fluidas.ro

Abstract: *The electronic module allows the acquisition of data for testing the steering boxes and transmitting them to an android device through a web interface. Power steering is one of the most requested options in a car of small and medium size, for the vehicles weighing over 1200 kg entirely common. In figure 1 is represented the percent's according to the type of assistance steering boxes; from this graph, in conjunction with the average age of the fleet in Romania (13 years in the year 2017), it is deduced that most power-steering's mounted on cars have hydraulic power steering or electro-hydraulic, so the need for a portable test equipment is needed to discover and resolve the problem regarding faults of the system without disassembling the vehicle. Advantage of the device lies in its capability to transmit data that is collected by flow and pressure transducers and sent to a mobile (smartphone or tablet) or fixed device (PC) using Wireless technology. Also data can be transmitted to an operator who is specializes in repairing hydraulic steering boxes to confirm their state of function.*

This article presents the electronic module for portable test equipment with data transmission for hydraulic power boxes and pumps from cars, this test device will have reduced dimensions and will be formed of a flow transducer and pressure transducer and a 2 way distributor with and a wireless module, all of which are connected to an electronic unit with an display located on the device panel. This data is then transmitted to a device that has a software application installed on it, capable of play back information that receives from the transducers.

Keywords: *Fault test, power steering, public safety, automotive*

1. Introduction

The main important part of the system is the Wi-Fi data transmitter and the program, which measure the pressure and the flow of the power steering system.

Wi-Fi is a popular wireless networking technology. Wi-Fi stands for “wireless fidelity”. The Wi-Fi was invented by NCR corporation/AT&T in Netherlands in 1991. By using this technology we can exchange the information between two or more devices. Wi-Fi has been developed for mobile computing devices, such has laptops, but it is now extensively using for mobile applications and consumer electronics like televisions, DVD players and digital cameras. There should be two possibilities in communicating with the Wi-Fi connection that may be through access point to the client connection or client to client connection. Wi-Fi is a one type of wireless technology. It is commonly called as wireless LAN (local area network). Wi-Fi allows local area networks to operate without cable and wiring. It is making popular choice for home and business networks. A computer's wireless adaptor transfers the data into a radio signal and transfers the data into antenna for users.

The main advantages of wising Wi-Fi technology in industrial applications is versatility and rapid communication between devices, in our case between the mobile test equipment for power starring systems and the smart device (smartphone, tablet, PC, etc.).

Advantages:

- Wireless devices can be moved from one place to another place
- Wi-Fi network communication devices without wire can reduce the cost of wires.
- Wi-Fi setup and configuration is easy than cabling process
- It is completely safe and it will not interfere with any network
- We can also connect internet via hot spots
- We can connect wirelessly to any device

2. Product description

The electronic module of portable test equipment is provided with data transmission, fig. 1, is a new product which allows testing of the hydraulic power steering system of vehicles without having to dismantle the subassemblies, thus reducing the immobilization time of the vehicle and possible hydraulic fluid drainage on the road, endangering the safety of the others involved in traffic. The device is also capable of transmitting data from pressure and flow sensors to a smartphone, tablet, or to desktop PC via a wireless module. It can also be produced with an integrated display for rendering the measured values as well as with the possibility of storing this information.

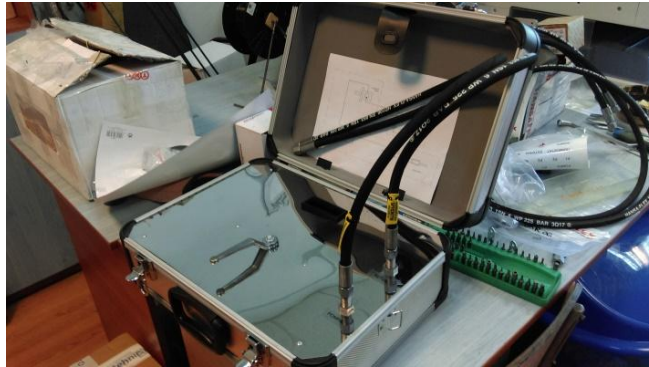

Fig. 1. The portable equipment

The usefulness of this equipment is due to the poor quality of roads in some areas that puts the power steering's under a lot of wear and tear, they over the operating limit designed by the manufacturer. This new device, very much needed in the field of repair and maintenance, it also reduces the time with the defects repair due to the flexibility offered by the data transmission system, with which information's can be sent to a repair specialist of the hydraulic power steering boxes. The device is also capable of generating a test report, which it can then be passed on to a specialist who can accurately determine the cause of the fault and the solution needed to repair the servo-hydraulic system. This portable test device is been produced in Romania being only one with sensors and data transmission. In fig.2 it can be seen a block diagram with the components of the portable test equipment and the informatics data transmission system and local display.

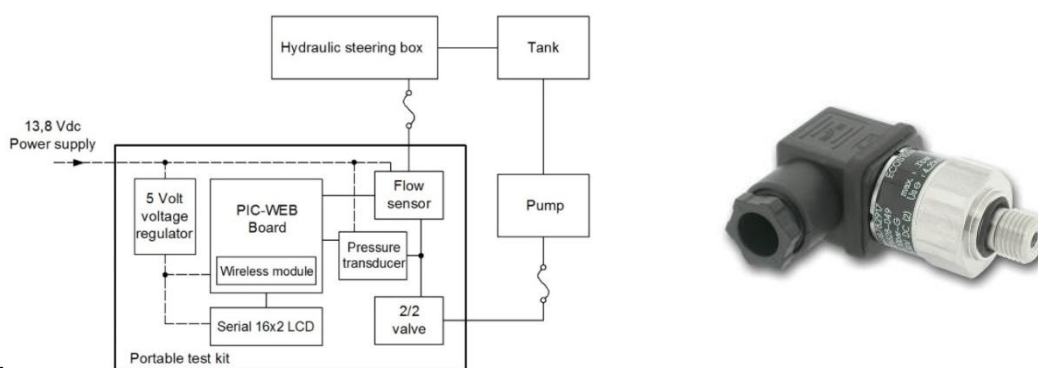

Fig. 2. Block diagram and the transducer circuit of portable test equipment with data transmission

The portable test equipment is composed of several sensors needed to record the parameters which are critical to determine the condition of the steering box. The sensors used in the hydraulic scheme are: pressure sensor with a domain of 0-160 bar, flow sensor 0,1-12 l/min [2]. All the sensors are connected to the input ports from Pic Web Board. The equipment is supplied with electricity from the cigarette lighter socket on the vehicle. Electrical connection of the microcontroller can be seen in figure 4. The pressure and flow transducer are powered by a voltage of 13.8 V, and the PIC-Web and the liquid-crystal electronic module are powered by 5 V via a voltage regulator integrated circuit. The pic-web module is provided with an optional wireless

transmission module connected via the UEXT connector. The display receives the data to be displayed through the serial port from the pic-web module to the RX pin.

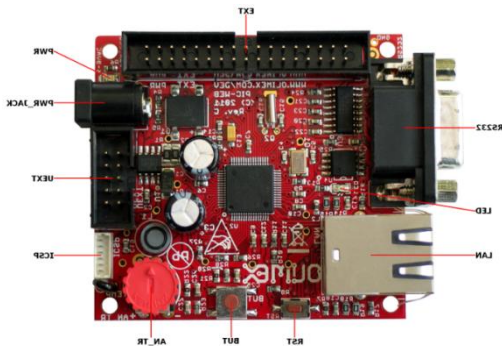

Fig. 3. The Pic-Web electronic development board from Olimex

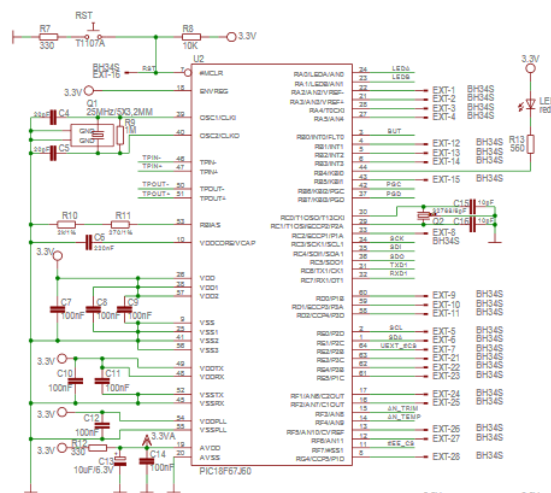

Fig. 4. The electronic diagram of the electronic module with microcontroller

Figure 3 shows the Pic-Web electronic development board from Olimex [3]. The Pic-Web board is designed to have Web page of no more than 128 kB. If necessary a lot of images in the application they can be stored on other server visible on the network where you have the PIC-WEB connected. The potential of the board is to generate a fluid communication between some specific sensors or actuators across a TCP/IP net including the controls of it.

Pic-Web board features:

- PIC18F67J60 microcontroller
- 1Mbit on board serial flash for web pages storage
- ICSP/ICD mini connector for programming and debugging with PIC-ICD2, PIC-ICD2-POCKET and PIC-ICD2-TINY.
- User event button
- Analogue trimmer potentiometer
- Thermistor for temperature monitoring
- RS232 driver and connector
- Complete web server and TCP-IP stack support as per Microchip's open source TCP-IP stack
- Power plug-in jack for DC power supply
- Voltage regulator +3.3V and filtering capacitors
- UEXT connector
- Extension header to connect to other boards
- Dimensions 60x65 mm (2.36x2.55")

3. Operation of the equipment

The test kit connects to the car's hydraulic assisted steering system with two hoses. Unscrew the hose that comes from the pump to the hydraulically assisted steering box and insert the equipment between the pump and the steering box. The built-in transducers will read the system pressure and flow. By closing the valve for a short time, the maximum pressure delivered by the steering pump can be determined. At the end of the stroke hydraulic cylinder piston, the steering box leakage can be determined.

All the tests are performed with the help of the software developed by Hydraulics and pneumatics research Institute with the aid of an internet protocol Web page program. Test data is displayed locally on the device panel fig.5 and transmitted wirelessly by the web application stored in the Pic-

Web module. Viewing test data and recording data is done by accessing the application through a web browser on any mobile device (phone or tablet). Connection of the mobile device to the web application is done wirelessly by accessing the IP address of the web application. Connecting to the web application can also be done with a desktop PC via an Ethernet cable, the Pic-Web module being equipped with an RJ45 Ethernet connector.

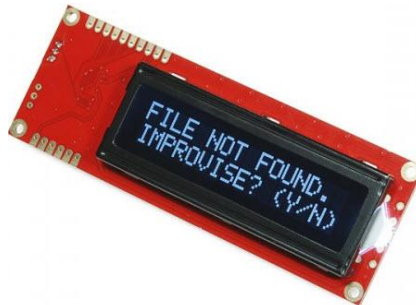

Fig. 5. Serial LCD display

All the data recorded it will be compared with those in the database and the system will decide whether the data recorded for the hydraulic steering box comply with the standards accepted by its manufacturer. In the software application page, the parameters obtained from the test can be seen and it is possible to record the data such as: name of the operator that perform testing, beneficiary of the test report, date and registration number of the test report. With this portable test device can be determined the rate of oil leakages at the stroke ends of steering box or in the middle of the stroke of hydraulic cylinder (the car wheels in the center position). The leakage rate is determined by the wear of the piston and rotary valve seals. The panel of the software application displays data obtained from testing. If the flow of loss at the end of stroke is above 1.5 l / min (fig.6) is recommended to replace or repair the steering box. A steering box worn, with large internal losses, will lead to disturbance in handling the power steering.

In order to issue the test report, in the software application the information for the beneficiary, the test operator and the test date must be noted. Once the data has been filled in, it will be possible to save a file containing the test parameters and identification data (report number, date, beneficiary, etc.).

The software it is design in a web browser that it can be modified to show the pressure and flow registered by the mobile test equipment's sensors, also the software it can make a process rapport that it can be sent by email or SMS directly to the power steering box parts supplier, ho figure the service needs of repair parts. Also the software can print the report for a documented evidence of the repair.

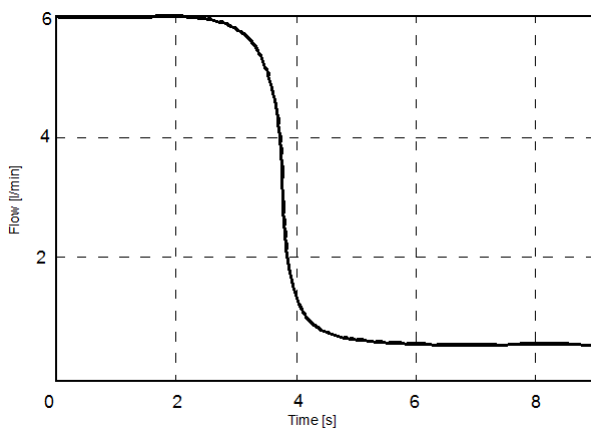

Fig. 6. Flow diagram

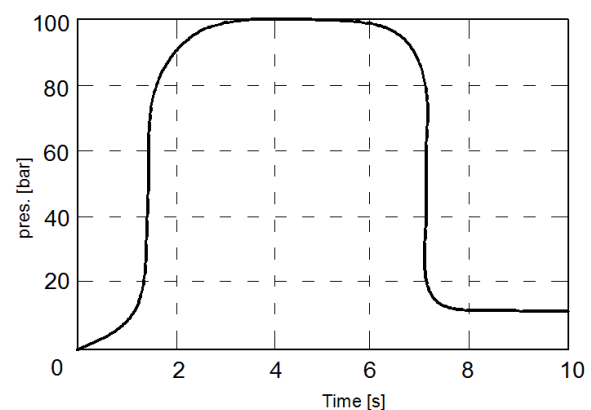

Fig. 7. Pressure diagram

4. Conclusions

The test portable equipment with data transmission allows quick testing of the hydraulically assisted steering system without the need to dismantle the parts from the car.

An advantage of the device lies in its capability to transmit data that is collected by flow and pressure transducers and sent to a mobile device (smartphone or tablet) or fixed (PC) using Wireless technology.

Through the web application can issue test reports with data transmitted wirelessly from the test equipment, which can then be archived.

The amount of sensors and the domain of them, determine how accurate is the report for increase the road safety and human loses due to malfunction of hydraulic power steering.

Acknowledgements

This work has been funded by Executive Unit for Financing Higher Education, Research, Development and Innovation - UEFISCDI, under PNCDI III - Programme 2, Subprogram 2.1 – Cheques of Innovation (CI-2017), Submission code PN-III-P2-2.1-CI-2017-0229, Financial agreement no. 3CI/2017, project title: Portable test equipment for the power steering of vehicles with data transmission, project acronym ETSAD, Project main domain: 2. Information of technology and communications space and security, Subdomain: 2.3. Security

References

- [1] P.A. Adegbuyi, I.L. Marcu, “Hydraulic and pneumatic cylinder failures, the effect of fluid cleanliness on component life”, *Hidraulica Magazine*, ISSN 1453-7303, Romania, no.1, pp. 27-30, 2013;
- [2] A. Marin, P. Drumea, M. Blejan, I. Ilie, “Informatics platform for determining the dynamic performances of a two stage servo valve”, *5th International Industrial Simulation Conference*, Delft, Netherlands, June 11-13, 2007, pp. 151-154, ISBN: 978-90-77381-34-2;
- [3] <https://www.olimex.com/Products/PIC/Development/PIC-WEB/resources/PIC-WEB-manual.pdf>.